

NEMEF

Project locks

NEMEF[®]

lock & cylinder technology

An ASSA ABLOY Group company

ASSA ABLOY

Lock & cylinder technology



NEMEF guarantees an extensive and continually growing assortment of locks and builders' hardware, such as door locks, profile cylinders, multi-point locks and access control. These quality products that leave the NEMEF plant reach their customers quickly and efficiently due to a hypermodern distribution centre. NEMEF is working today on the standard for tomorrow through innovative product development focused on contemporary user convenience.

Project locks

The proven utility of NEMEF project locks

The project building business asks for reliable locks and builders' hardware, which fulfil the highest quality demands and which are also easy to install. Especially for internal doors, NEMEF has developed a wide range of project locks, which are particularly suitable for heavy and frequent usage.

The locks, which are specified as per DIN 18251 part 1, or are manufactured according to the dimensions in this standard, are divided into several series, each with their own specific characteristics: the standard 1030 series (Class II), the heavy-duty 1060 series (Class III) and the extra heavy-duty 7000 series (Class III and IV), which are all handed, and the simple 340 series, standard 6600 series and the extra heavy-duty 6100 series, which are all reversible. All project locks are suitable for use with NEMEF project furniture in brass, aluminium or stainless steel. For this reason, NEMEF project locks have already been used on a large scale for many years. Therefore, NEMEF guarantees a technical longevity on their project locks.

Advantages of NEMEF locks

- All locks in a series have the same lock case dimensions. This means that all doors have the same mortice cut-out irrespective of which lock function is installed. Security lock versions are also available with the same case dimensions.
- The interior parts are zinc-plated and wear-resistant and therefore guarantee a long life.
- The locks are maintenance free due to thermally stable lubrication.
- Latch and dead bolt are made of high quality material.
- The clamping follower, in the 1060 and 7000 series, is bearing mounted and provides much more smoothness and durability.



The heavy-duty follower spring, in the locks that are Class III, are made from sintered spring steel so that lever handles will not hang.

DIN Schedule

Main features DIN 18251 – part 1			
after the tests the locks must still be operational			
	class 2	class 3	class 4
Lateral force on latch	3kN	3kN	5kN
Lateral force on dead bolt	4kN	6kN	10kN
Strength bolt detention	-	2kN	4kN
Cycle test latch bolt	-	200.000	200.000
Cycle test dead bolt	-	50.000	50.000
Key action on latch bolt	-	200.000	200.000
Lever force	-	50Nm	50Nm

340 series



Mortice lock DIN 18251 – part 1

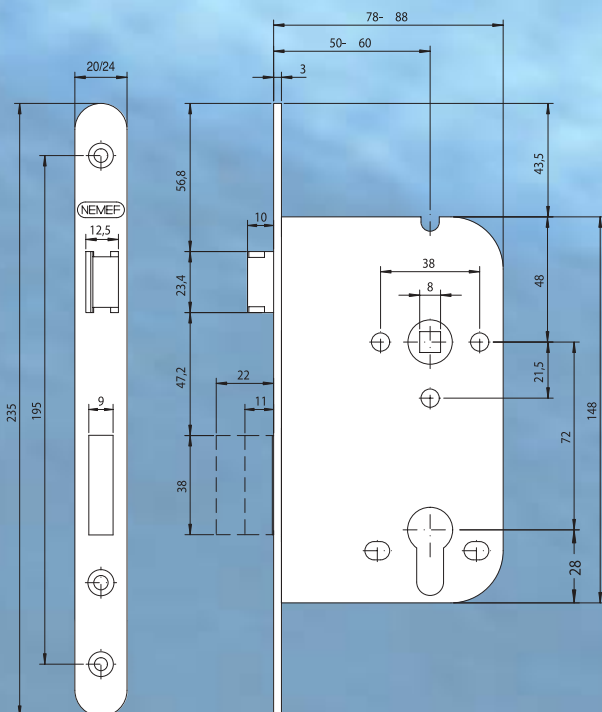

Lock functions

349 Sash lock/entrance lock

348 Dead lock

345 Latch

344 Bathroom/wc lock

Specifications

- Steel, grey lacquered case
- Lock dimensions according to DIN 18251 – part 1
- Centres 72 mm (bathroom/wc lock 78 mm)
- Backset 50/60 mm
- Front plate 24x235 mm stainless steel rounded or square, 20x235 mm stainless steel rounded
- 24x235 mm brushed brass rounded or square
- Die-cast zinc-plated follower 8 mm
- Easily reversible latch bolt
- Packed per piece, including strike plate and screws
- Key action on latch bolt
- Die-cast nickel-plated latch and dead bolt

1060 series



Heavy-duty mortice lock DIN 18251 – part 1, Class III

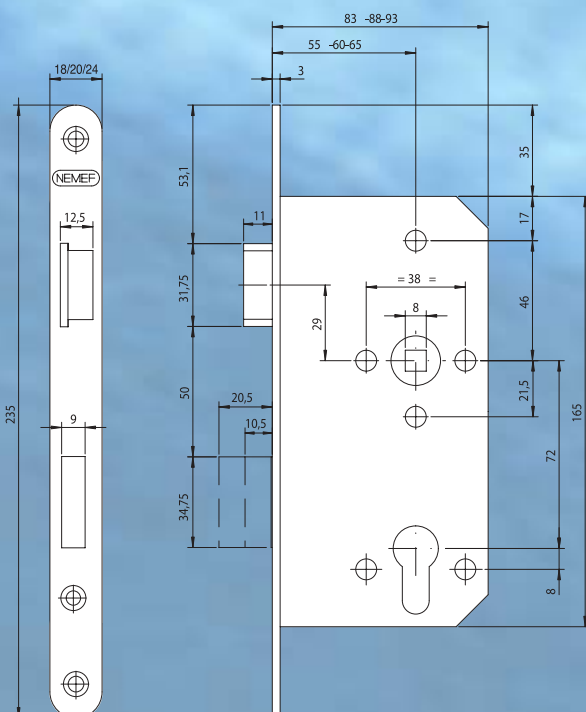

Lock functions

1069 Sash lock/entrance lock

1063 Dead lock

1065 Latch

1064 Bathroom/wc lock

Finish front plate

- 18/20/24 x 235 mm: steel, bronze or silver lacquered, rounded and square with die-cast zinc-plated latch and dead bolt
- 20/24 x 235 mm: brushed brass, rounded and square, with die-cast bright nickel-plated latch and dead bolts
- 20/24 x 235 mm: stainless steel, rounded and square, with die-cast bright nickel-plated latch and dead bolt

Specifications

- Steel zinc-plated lock case
- Backset 50/60/65 mm
- Centres 72 mm (bathroom/wc lock 78 mm)
- 2-pieced steel clamping follower 8 mm
- With key action on latch bolt
- Handed
- Packed per piece, without strike plate

Option

- Blocking of the latch by key action on latch

Project locks

7000 series *** standard



Extra heavy-duty mortice lock DIN 18251 - part 1, Class III

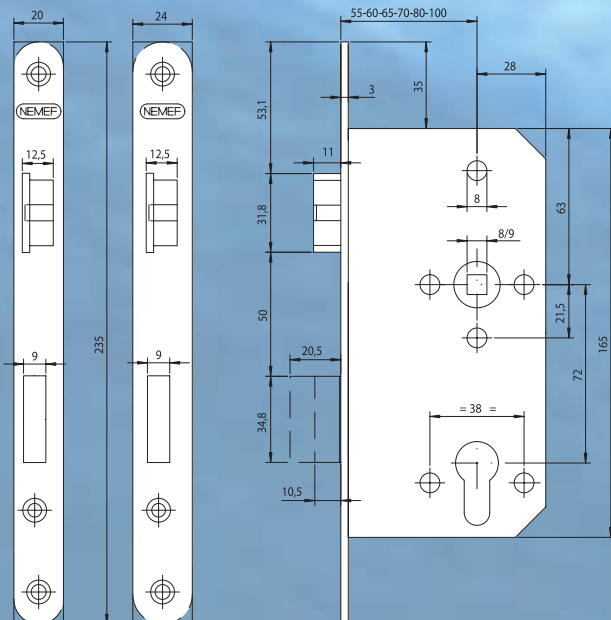
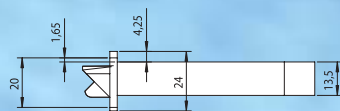

Lock functions

- 700 Sash lock/entrance lock
- 702 Dead lock
- 703 Latch
- 704 Bathroom/wc lock

Specifications

- Zinc-plated lock case
- Backset 55/60/65/70/80/100 mm
- Centres 72 mm (bathroom/wc lock 78 mm)
- 2-pieced steel clamping follower 8/9 mm
- Plastic bearing when backset 55/60/65 mm is used
- Steel bearing when backset 70/80/100 mm is used
- Latch die-cast bright nickel-plated with noise reduction
- Dead bolt die-cast bright nickel-plated
- Front plate 20/24 x 235 mm rounded or square
- Finish of front plate: steel bronze lacquered, stainless steel or polished brass
- Front plate stamped with ***
- Packed per piece, without strike plate

Options

- Steel bearing
- Anti-friction latch bolt (finish depends on front plate)
- Front plate silver lacquered
- Roller bolt lock

7000 series * heavy-duty**



Extra heavy-duty mortice lock DIN 18251 - part 1, Class III

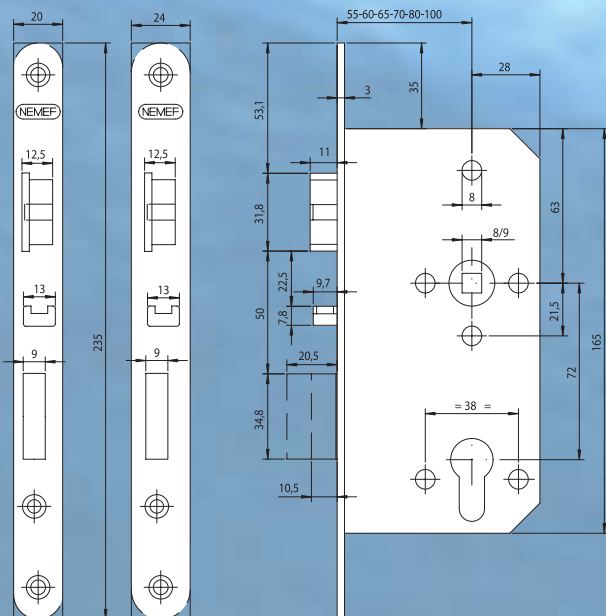
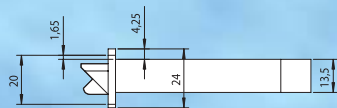

Lock functions

- 710 Sash lock/entrance lock
- 712 Dead lock
- 713 Latch
- 714 Bathroom/wc lock
- 715 Panic lock
- 717 Hotel lock (backset 65 mm only)
- 718 X-ray lock (backset 40/80 mm only)

Specifications

- Zinc-plated lock case
- Backset 55/60/65/70/80/100 mm
- Centres 72 mm (bathroom/wc lock 78 mm)
- Latch sintered steel or brass
- Dead bolt steel or brass
- 2-pieced steel clamping follower 8/9 mm
- Steel bearing
- Latch bolt with noise reduction
- Front plate stamped with ***
- Key action on latch bolt
- Handed
- Packed per piece, without strike plate
- Front plate 20/24 x 235 mm: stainless steel or polished brass lacquered, rounded or square

Only available with a minimum one of the options listed below:

- Sintered steel nickel-plated anti-friction latch bolt (for stainless steel finish)
- Brass polished anti-friction latch bolt (for brass finish)
- Brass nickel-plated auxiliary latch (for ss finish)
- Brass polished auxiliary latch (for brass finish)
- Sintersteel nickel-plated anti-friction latch bolt and brass nickel-plated auxiliary latch (for ss finish)
- Brass polished anti-friction latch bolt and auxiliary latch (for brass finish)
- Latch blocking mechanism

Project locks

7000 series * * * * standard



Extra heavy-duty mortice lock DIN 18251 - part 1, Class IV

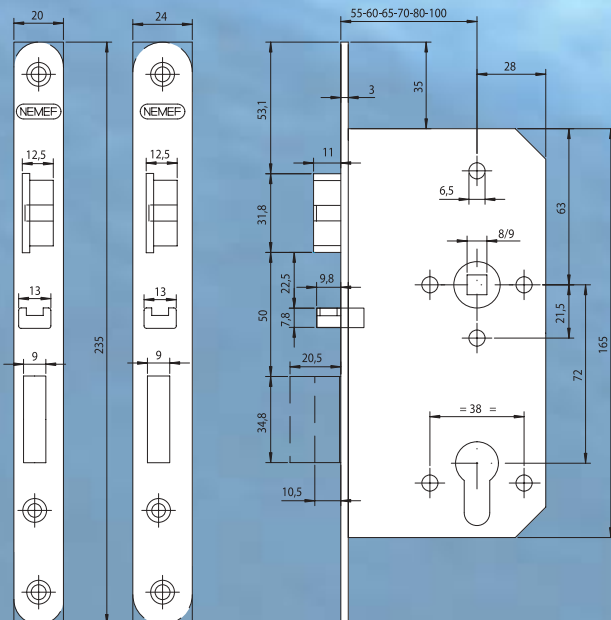
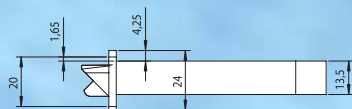

Lock functions

- 740 Sash lock/entrance lock
- 742 Dead lock
- 743 Latch
- 744 Bathroom/wc lock
- 746 Roller bolt lock
- 745 Panic lock
- 747 Hotel lock (backset 65 mm only)
- 748 X-ray lock (backset 40/80 mm only)

Specifications

- Zinc plated white lacquered lock case
- Backset 55/60/65/70/80/100 mm
- Centres 72 mm (bathroom/wc lock 78 mm)
- 2-pieced steel clamping follower 8/9 mm
- Steel bearing
- 6 bushings per lock (except the x-ray lock)
- Latch with noise reduction
- Front plate
 - Finishes brass polished lacquered in combination with brass polished latch and/or dead bolt
 - Stainless steel grinded in combination with steel bright nickel-plated latch and/or dead bolt
- Key action on latch bolt
- Handed
- Packed per piece, without strike plate

Options

- Hold back function on the latch
- For stainless steel finish
 - Sinter steel nickel-plated anti-friction latch
 - Brass nickel-plated auxiliary latch
 - Sintersteel nickel-plated anti-friction latch and brass nickel-plated auxiliary latch
- For brass finish
 - Brass polished anti-friction latch
 - Brass polished auxiliary latch
 - Brass polished anti-friction latch and auxiliary latch

6600 series



Dimensions according to DIN 18251 – part 1 (Class III)
heavy-duty project lock non-handed

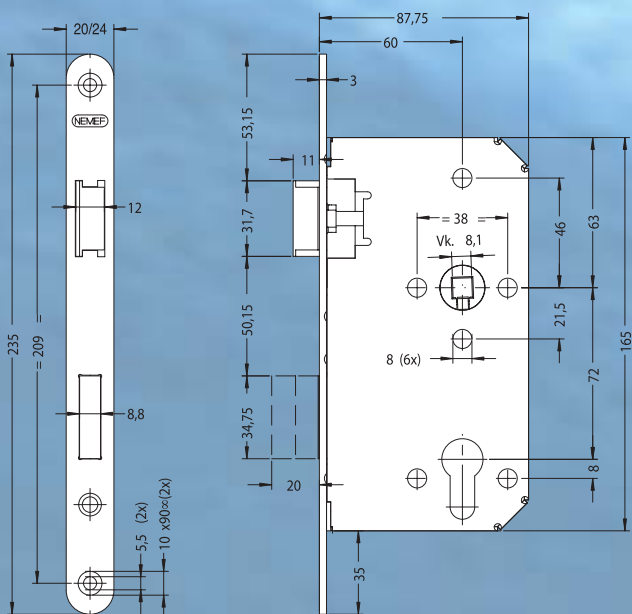

Lock functions

6602 Sash lock/entrance lock

6622 Dead lock

6632 Latch

6642 Bathroom/wc lock

Specifications

- Zinc-plated lock case
- Backset 60 mm
- Centres 72 mm (bathroom/wc lock 78 mm)
- Die-cast nickel plated bolts
- Steel clamping follower 8 mm
- Front plate 20/24 x 235 mm rounded or square, lacquered or stainless steel
- Key action on latch bolt
- Easily reversible latch bolt
- Packed per piece, including strike plate and screws

Project locks

6100 series



Dimensions according to DIN 18251 – part 1 (Class III)
extra heavy-duty project lock non-handed

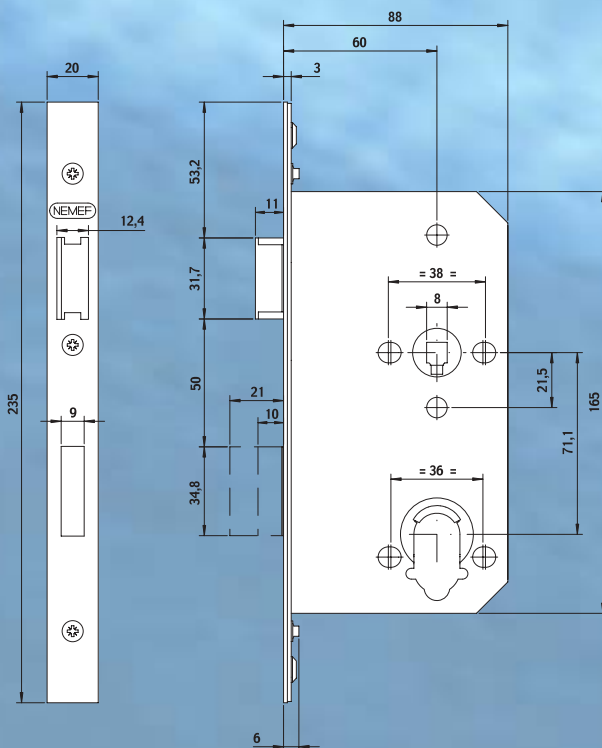

Lock functions

- 6109 Sash lock/entrance lock
- 6108 Dead bolt lock
- 6105 Latch
- 6107 Night latch
- 6106 Night latch with hold back function
- 6104 Bathroom/wc lock
- 6102 Panic lock (in development)

Specifications

- Zinc-plated white lacquered lock case
- Backset 60 mm
- Centres 72 mm (bathroom/wc lock 78 mm)
- Sintersteel latch and dead bolt
- Forend 20 x 235 mm, square stainless steel
- 2-pieced steel clamping follower 8 mm
- Extra heavy-duty counter spring
- Suitable for oval as well as euro profile cylinder
- Key action on latch bolt
- Certified for 4 hours fire-resistant according to BS 476 part 22, 1997, clause 8
- Easily reversible latch bolt
- Packed per piece, including strike plate, screws and mounting instructions

Suitable strike plates

340 series

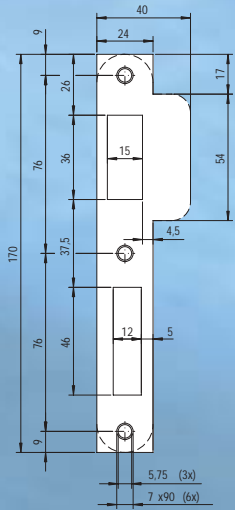

P344/349 (square and rounded)

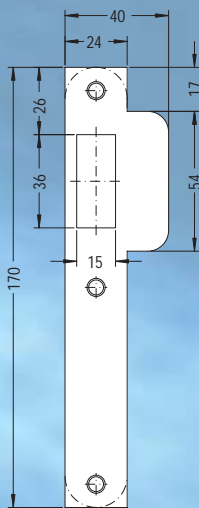

P345 (square and rounded)

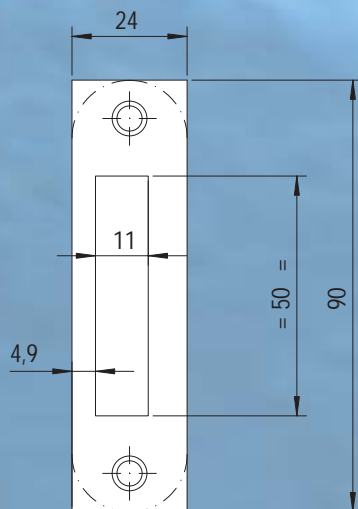

P348 (square and rounded)

1030 series

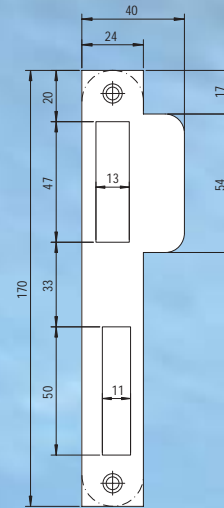

P1036 (square and rounded)

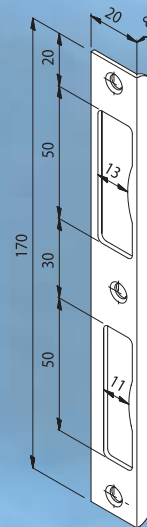

HP1036 (square and rounded)

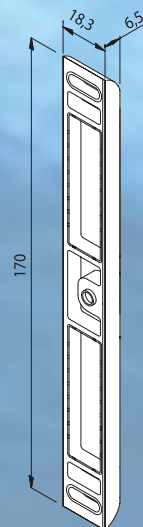

SK1036 (square and rounded)



combination HP and SK

Project locks

Suitable strike plates

1060/7000 series

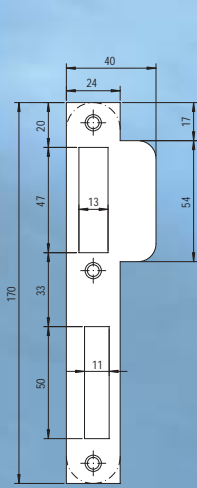

P7000 (square and rounded)

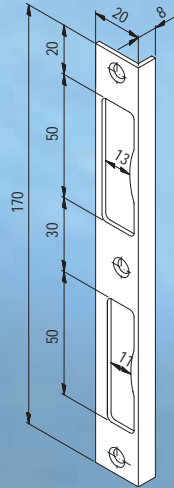

HP7000 (square and rounded)

1060/7000 series

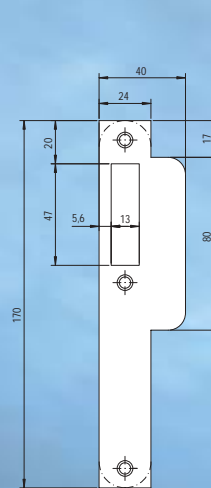

P7003 for auxiliary latch (square and rounded)

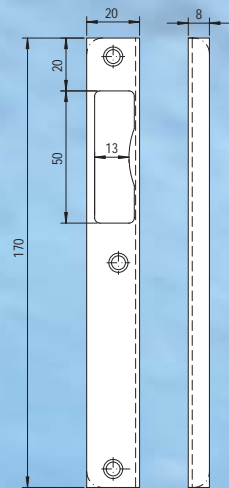

HP7003 (square and rounded)

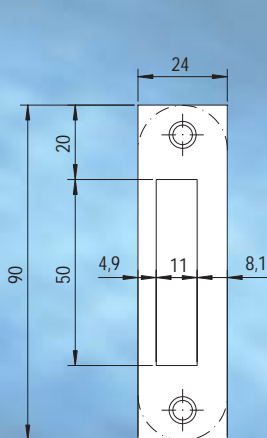

P7002 (square and rounded)

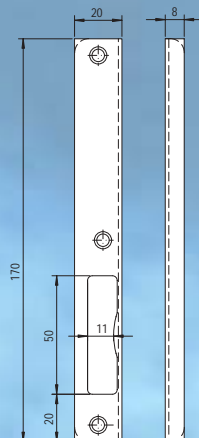

HP7002 (square and rounded)

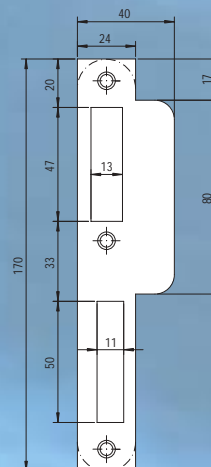

P7200 (square and rounded)

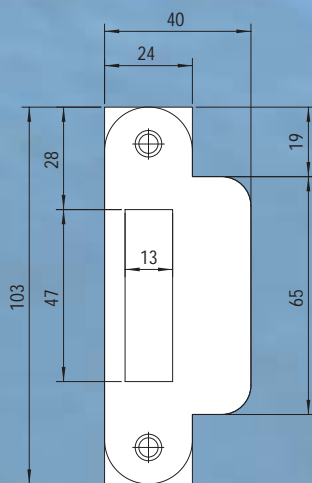

P7003 (square and rounded)

1060 series

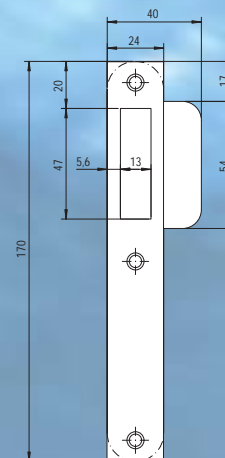

P1065 (square and rounded)

Suitable strike plates

6600 series

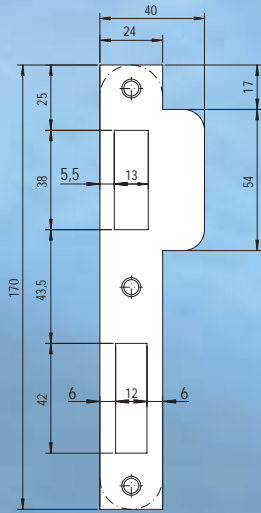

P6602 (square and rounded)

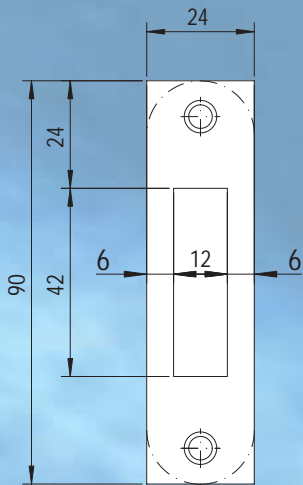

P6622 (square and rounded)

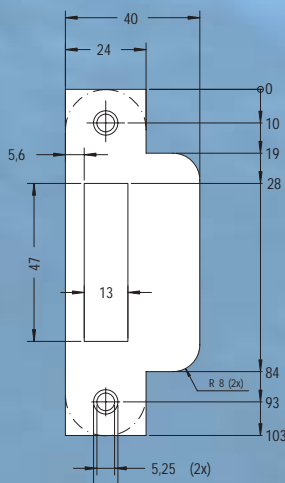

P6632 (square and rounded)

6100 series

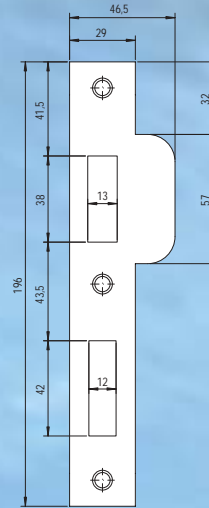

P6109 (square)

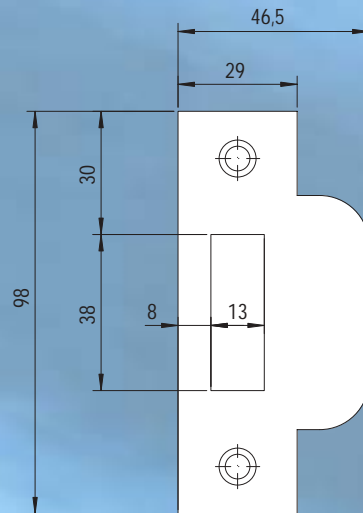

P6105 (square)

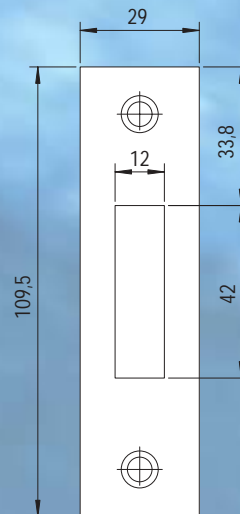

P6108 (square)



l o c k & c y l i n d e r t e c h n o l o g y

NEMEF BV P.O. Box 13, 7300 AA Apeldoorn, The Netherlands

Telephone +31 55 312 84 00 Telefax +31 55 312 20 87 E-mail info@nemef.nl Internet www.nemef.nl

An ASSA ABLOY Group company

ASSA ABLOY

The ASSA ABLOY Group is the world's leading manufacturer and supplier of locking solutions,
dedicated to satisfying end-user needs for security, safety and convenience.